

Current Electricity

Fill Ups, True/False

Q.1. An electric bulb rated for 500 watts at 100 volts is used in a circuit having a 200 volts supply. The resistance R that must be put in series with the bulb, so that the bulb delivers 500 watt isohm.

Ans. 20

Solution. We know that $P = \frac{V^2}{R}$

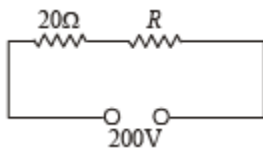

$$\therefore R = \frac{V^2}{P} = \frac{100 \times 100}{500} = 20 \Omega$$

NOTE : For the bulb to deliver 500 W, it should have a p.d. of 100 V across it. This would be possible only when $R = 20 \Omega$ is in series with the bulb because in that case both resistances will share equal p.d.

Q.2. The equivalent resistance between points A and B of the circuit given below is Ω .

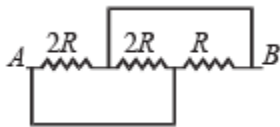

Ans. $R/2$

Solution. The given circuit may be redrawn as shown in the figure. Thus, the resistances $2R$, $2R$ and R are in parallel.

$$\text{Hence, } \frac{1}{R_{AB}} = \frac{1}{2R} + \frac{1}{2R} + \frac{1}{R} = \frac{2}{R}$$

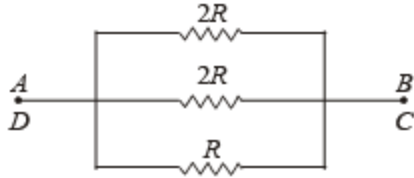

Hence, $R_{AB} = \frac{R}{2}$

Q.3. In the circuit shown below, each battery is 5V and has an internal resistance of 0.2 ohm.

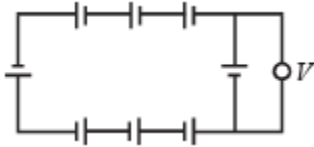

The reading in the ideal voltmeter V is V.

Ans. 0

Solution. Let a current I flow through the circuit. Net emf of the circuit = $8 (5V) = 40 V$

Net resistance in the circuit = $8 (0.2 \Omega) = 1.6 \Omega$ Current flowing through the circuit,

$$I = \frac{40V}{1.6\Omega} = 25 A$$

The voltmeter reading would be $V = E - IR = (5V) - (25A) (0.2 \Omega) = 5V - 5V = 0$

True/ False

Q.1. In an electrolytic solution the electric current is mainly due to the movement of free electrons.

Ans. F

Solution. NOTE : An electrolyte solution is formed by mixing an electrolyte in a solvent. The electrolyte on dissolution furnishes ions. The preferred movement of ions under the influence of electric field is responsible for electric current.

Q.2. Electrons in a conductor have no motion in the absence of a potential difference across it.

Ans. f

Solution. NOTE : Billions of electrons in a conductor are free and have thermal velocities. The electrons have motion in random directions even in the absence of potential difference.

Q.3. The current –voltage graphs for a given metallic wire at two different temperatures T_1 and T_2 are shown in the figure.

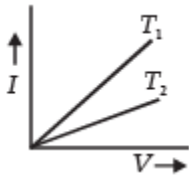

The temperature T_2 is greater than T_1 .

Ans. T

Solution. For a given voltage, current is more in case of T_1 .

Since, $V = IR$

$$\therefore R = \frac{V}{I}$$

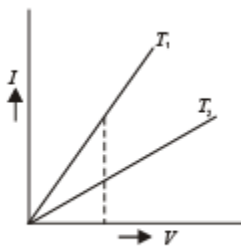

Resistance is less in case of T_1 and more in T_2 .

NOTE : For a metallic wire, resistance increases with temperature, therefore $T_2 > T_1$

Subjective Questions

Q.1. A heater is designed to operate with a power of 1000 watts in a 100 volt line. It is connected in a combinations with a resistance of 10 ohms and a resistance R to a 100 volts mains as shown in the figure. What should be the value of R so that the heater operates with a power of 62.5 watts.

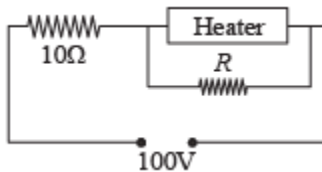

Ans. 5Ω

Solutions. The resistance of the heater is

$$R = \frac{V^2}{P} = \frac{100 \times 100}{1000} = 10\Omega$$

The power on which it operates is 62.5 W

$$\therefore V = \sqrt{R \times P'} = \sqrt{10 \times 62.5} = \sqrt{625} = 25$$

Since the voltage drop across the heater is 25V hence voltage drop across 10Ω resistor is $(100 - 25) = 75\text{V}$.

$$\therefore \text{The current in } AB = I = \frac{V}{R} = \frac{75}{10} = 7.5\text{A}$$

This current divides into two parts. Let I_1 be the current that passes through the heater. Therefore

$$25 = I_1 \times 10$$

$$I_1 = 2.5\text{A}$$

Thus current through R is 5A.

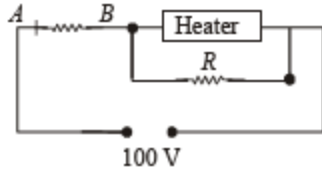

Applying Ohm's law across R, we get $25 = 5 \times R$

$$\Rightarrow R = 5\Omega$$

Q.2. If a copper wire is stretched to make it 0.1% longer what is the percentage change in its resistance?

Ans. 0.2%

Solutions.

$$\frac{R_f - R_i}{R_i} \times 100 = \frac{\rho \frac{\ell_f}{A_f} - \rho \frac{\ell_i}{A_i}}{\rho \frac{\ell_i}{A_i}} \times 100$$

$$= \frac{\frac{\ell_f}{A_f} - \frac{\ell_i}{A_i}}{\frac{\ell_i}{A_i}} \times 100 \quad \dots (i)$$

Let the initial length of the wire be 100 cm, then the new

$$\text{length is } 100 + \frac{0.1}{100} \times 100$$

$$l_f = 100.1 \text{ cm} \quad \dots (ii)$$

Let A_i and A_f be the initial and final area of cross-section.

Then

$$100 \times A_i = 100.1 A_f$$

$$\Rightarrow A_f = \frac{100}{100.1} A_i \quad \dots (iii)$$

From (i), (ii) and (iii)

$$\frac{R_f - R_i}{R_i} \times 100 = \frac{\frac{(100.1)^2}{100} - \frac{100}{A_i}}{\frac{100}{A_i}} \times 100$$

$$= \frac{(100.1)^2 - (100)^2}{(100)^2} \times 100 = \frac{200.1 \times 0.1}{100 \times 100} \times 100$$

$$= 0.2\%$$

Thus the resistance increases by 0.2%.

Alternatively for small change $\frac{\Delta R}{R} = \frac{\Delta A}{A} + \frac{\Delta \ell}{\ell}$

Q.3. All resistances in the diagram below are in ohms. Find the effective resistance between the points A and B.

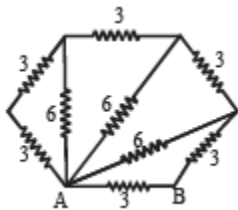

Ans. 2Ω

Solution.

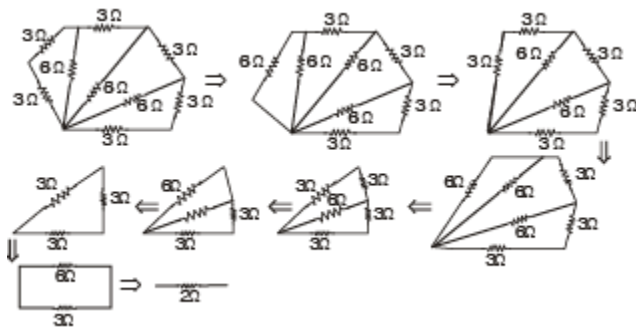

Q.4. In the diagram shown find the potential difference between the points A and B and between the points B and C in the steady state.

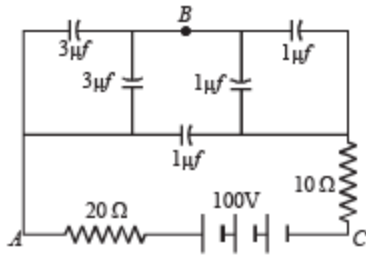

Ans. $V_{AB} = 25 \text{ V}$, $V_{BC} = 75 \text{ V}$

Solution. Applying Kirchoff's law in loop AQBRC

$$-\frac{q}{6} - \frac{q}{2} + 100 = 0$$

$$\Rightarrow q = 150 \mu\text{C}$$

\therefore Potential difference between AB = $150/6 = 25\text{V}$

\therefore Potential difference between BC = $100 - 25 = 75\text{V}$

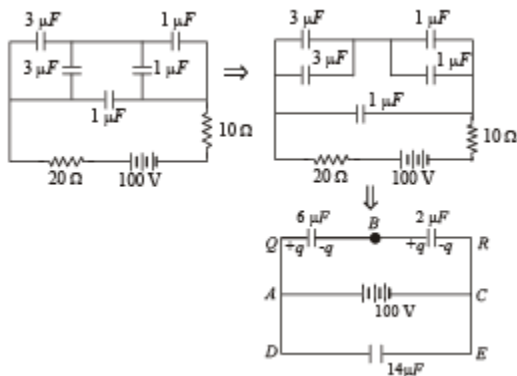

Q.5. A battery of emf 2 volts and internal resistance 0.1 ohm is being charged with a current of 5 amps. In what direction will the current flow inside the battery? What is the potential difference between the two terminal of the battery?

Ans. Positive to negative terminal, 2.5 V

Solution. NOTE : The current will flow from the positive terminal to the negative terminal inside the battery.

During charging the potential difference $V = E + Ir = 2 + 5 \times 0.1 = 2.5 \text{ V}$



Q.6.State ohm's law.

In the circuit shown in figure, a voltmeter reads 30 volts when it is connected across 400 ohm resistance. Calculate what the same voltmeter will read when it is connected across the 300 ohm resistance.

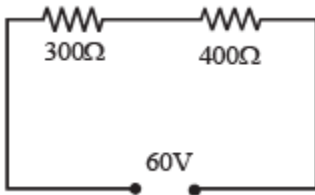

Ans.22.5 V

Solution. Potential difference across the 400 Ω resistance = 30 V.

Therefore, potential difference across the 300 Ω resistance = 60 – 30V = 30 V. Let R be the resistance of the voltmeter.

As the voltmeter is in the parallel with the 400Ω resistance, their combined resistance is

$$R' = \frac{400R}{(400 + R)}$$

As the potential difference of 60 V is equally shared between the 300 Ω and 400 Ω resistance. R' should be equal to 300 Ω.

Thus

$$300 = \frac{400R}{(400 + R)}$$

which gives R = 1200Ω, is the resistance of the voltmeter.

When the voltmeter is connected across the 300Ω resistance, their combined resistance is

$$R'' = \frac{300R}{(300 + R)} = \frac{300 \times 1200}{(300 + 1200)} = 240\Omega$$

∴ Total resistance in the circuit = 400 + 240 = 640 Ω

∴ Current in the circuit is

$$I = \frac{60V}{640\Omega} = \frac{3}{32}A$$

∴ Voltmeter reading = Potential difference across 240Ω resistance

$$= \frac{3}{32} \times 240 = 22.5V$$

Q.7. In the circuit shown in fig $E_1 = 3$ volts, $E_2 = 2$ volts, $E_3 = 1$ volt and $R = r_1 = r_2 = r_3 = 1$ ohm.

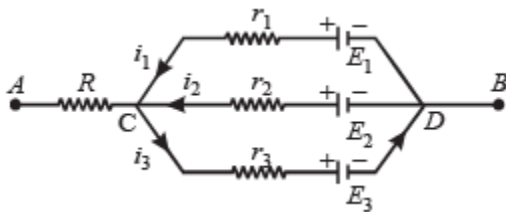

(i) Find the potential difference between the points A and B and the currents through each branch.

(ii) If r_2 is short circuited and the point A is connected to point B, find the currents through E_1 , E_2 , E_3 and the resistor R

Ans.(i) 2V, 1A, 0A, 1A (ii) 1A, 2A, 1A; 2A

Solution.

$$(i) V_{AB} = \frac{\sum E/r}{\sum \frac{1}{r}} = \frac{\frac{E_1}{r_1} + \frac{E_2}{r_2} + \frac{E_3}{r_3}}{\frac{1}{r_1} + \frac{1}{r_2} + \frac{1}{r_3}}$$

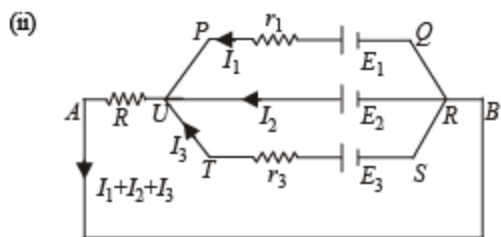

Applying Kirchoff's law in PQRUP starting from P moving clockwise

$$I_1 r_1 - E_1 + E_2 = 0 \quad \text{or} \quad I_1 - 3 + 2 = 0$$

or $I_1 = 1 \text{ amp}$

Applying Kirchoff's law in URSTU starting from U moving clockwise

$$-E_2 + E_3 - I_3 r_3 = 0$$

or $-2 + 1 - I_3 = 0$

or $I_3 = -1 \text{ amp}$

NOTE : The - ve sign of I_3 indicates that the direction of current in branch UTSR is opposite to that assumed.

Applying Kirchoff's law in AURBA starting from A moving clockwise.

$$(I_1 + I_2 + I_3) R - E_2 = 0 \quad \text{or} \quad (1 + I_2 - 1) R = 2$$

or $I_2 = 2 \text{ amp}$

Current through R is $I_1 + I_2 + I_3 = 2A$

Q.8. Calculate the steady state current in the 2-ohm resistor shown in the circuit in the figure. The internal resistance of the battery is negligible and the capacitance of the condenser C is 0.2 microfarad.

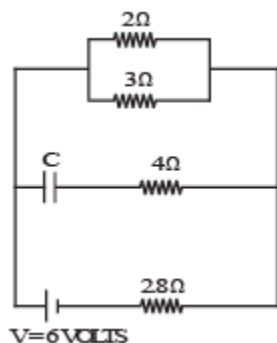

Ans. 0.9A

Solution. $(R_{eq})_{AB} = \frac{2 \times 3}{2+3} = 1.2 \Omega$

Total current through the battery

$$= \frac{6}{1.2+2.8} = 1.5A \quad \therefore \quad I_1 = \frac{3}{5} \times 1.5 = 0.9A$$

Q.9. In the circuit shown in figure E, F, G, H are cells of emf 2, 1, 3 and 1 volt respectively, and their internal resistances are 2, 1, 3 and 1 ohm respectively.

Calculate : (i) the potential difference between B and D and

(ii) the potential difference across the terminals of each cells G and H

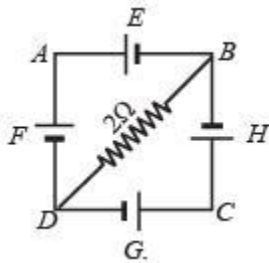

Ans. (i) $\frac{2}{13} V$ (ii) $\frac{21}{13} V, \frac{19}{13} V$

Solution. Let I_2 current flow through the branch DCB

\therefore By Kirchoff's junction law, current in branch DB will be $I_2 - I_1$ as shown in the figure.

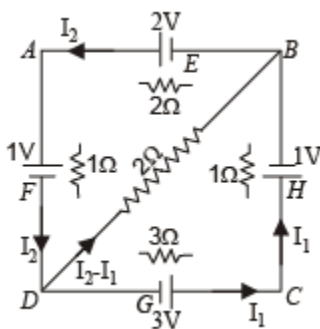

Applying Kirchoff's law in loop BDAB

$$\begin{aligned} &+2(I_2 - I_1) + 1 + 1 \times I_2 - 2 + 2I_2 = 0 \\ \Rightarrow &2I_1 - 5I_2 = -1 \quad \dots \text{(i)} \end{aligned}$$

Applying Kirchoff's law in loop BCDB, we get

$$\begin{aligned} &-2(I_2 - I_1) + 1 + I_1 - 3 + 3I_1 = 0 \\ \Rightarrow &3I_1 - I_2 = 1 \quad \dots \text{(ii)} \end{aligned}$$

Solving (i) and (ii), we get $I_1 = 6/13$ amp

and $I_2 = 5/13$ amp

(i) To find the p.d. between B and D, we move from B to D

$$V_B + \left[\frac{5}{13} - \frac{6}{13} \right] \times 2 = V_D \quad \therefore V_B - V_D = \frac{2}{13} \text{ volt}$$

$$\text{(ii) p.d. across } G = 3 - \frac{6}{13} \times 3 = \frac{39 - 18}{13} = \frac{21}{13} \text{ volt}$$

[\therefore the cell is in discharging mode]

$$\text{p.d. across } H = 1 + 1 \times \frac{6}{13} = \frac{19}{13} \text{ volt}$$

[\therefore cell is in charging mode]

Q.10. A part of circuit in a steady state along with the currents flowing in the branches, the values of resistances etc., is shown in the figure. Calculate the energy stored in the capacitor C ($4\mu\text{F}$)

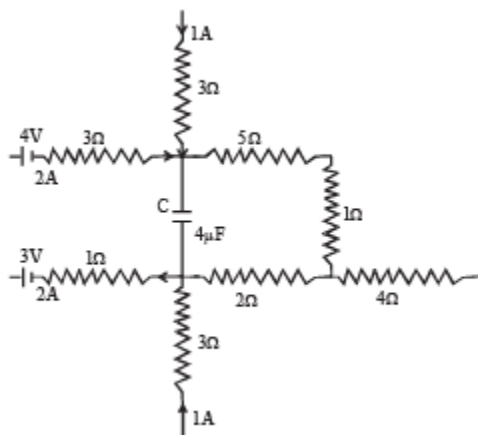

Ans. $8 \times 10^{-4} \text{ J}$

Solution. Applying Kirchoff's first law at junction M, we get the current $i_1 = 3 \text{ A}$

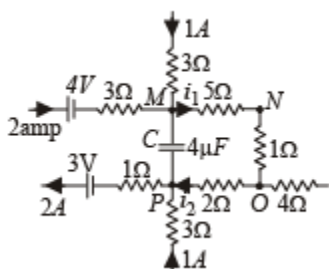

Applying Kirchoff's first law at junction P, we get current $i_2 = 1 \text{ A}$

NOTE : No current flows through capacitor at steady state.

Moving the loop along MNO to P

$$\begin{aligned} \therefore V_M - 5 \times i_1 - 1 \times I_1 - 2 \times i_2 &= V_P \\ \therefore V_M - V_P &= 6i_1 + 2i_2 = 6 \times 3 + 2 \times 1 = 20 \text{ V} \\ \therefore V &= 6 \times 3 + 2 \times 1 = 20 \text{ V} \end{aligned}$$

Energy stored in the capacitor

$$= \frac{1}{2} CV^2 = \frac{1}{2} \times 4 \times 10^{-6} \times 20 \times 20 = 8 \times 10^{-4} \text{ J}$$

Q.11. An infinite ladder network of resistances is constructed with a 1 ohm and 2 ohm resistances, as shown in fig.

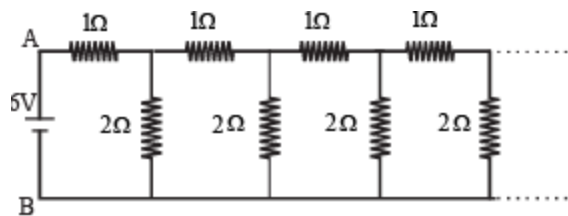

The 6 volt battery between A and B has negligible internal resistance : (i) Show that the effective resistance between A and B is 2 ohms. (ii) What is the current that passes through the 2 ohm resistance nearest to the battery ?

Ans.(ii) 1.5A

Solution. (i) Let the effective resistance between points C and D be R then the circuit can be redrawn as shown The effective resistance between A and B is

$$R_{eq} = 1 + \frac{2 \times R}{R + 2}$$

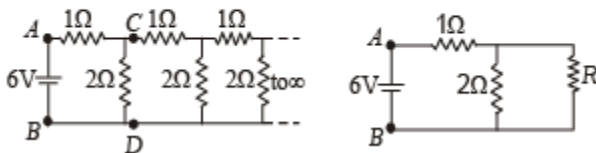

This resistance R_{eq} can be taken as R because if we add one identical item to infinite items then the result will almost be the same.

$$\begin{aligned} \therefore 1 + \frac{2 \times R}{R + 2} &= R \\ \Rightarrow R + 2 + 2R &= R^2 + 2R \Rightarrow R^2 - R - 2 = 0 \\ \Rightarrow R^2 - 2R + R - 2 &= 0 \\ \Rightarrow R(R - 2) + 1(R - 2) &= 0 \\ \Rightarrow [R + 1][R - 2] &= 0 \Rightarrow R = 2\Omega. \end{aligned}$$

$$(ii) R_{AB} = 1\Omega + 1\Omega = 2\Omega \therefore I_{AB} = \frac{6}{2} = 3 \text{ Amp.}$$

$$\begin{aligned} \text{Further, } i_{CD} &= i_{CF} \text{ as resistances } R_{CD} = R_{CF} \\ \therefore i_{CD} &= i_{CF} = 1.5 \text{ A} \end{aligned}$$

Q.12.In the given circuit

$$E_1 = 3E_2 = 2E_3 = 6 \text{ volts } R_1 = 2R_4 = 6 \text{ ohms } R_3 = 2R_2 = 4 \text{ ohms } C = 5 \mu \text{ f .}$$



Find the current in R3 and the energy stored in the capacitor.

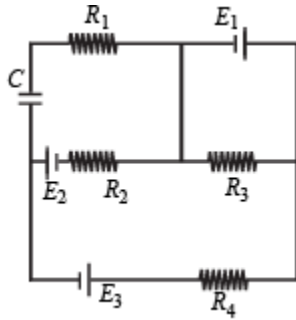

Ans. 1.5 A, 1.44×10^{-5} J

Solution.

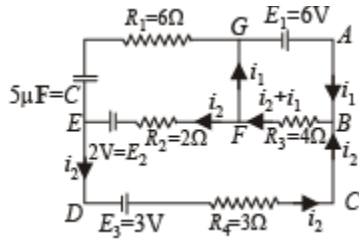

Applying Kirchoff's law in ABFGA $6 - (i_1 + i_2) 4 = 0 \dots$ (i)

Applying Kirchoff's law in BCDEFB $i_2 \times 3 - 3 - 2 + 2i_2 + (i_2 + i_1) 4 = 0 \dots$ (ii)

Putting the value of $4(i_1 + i_2) = 6$ in (ii)

$$3i_2 - 5 + 2i_2 + 6 = 0$$

$$\therefore i_2 = -\frac{1}{5}A$$

Substituting this value in (i), we get

$$i_1 = 1.5 - \left(-\frac{1}{5}\right) = 1.7A$$

Therefore current in R3

$$= i_1 + i_2 = 1.7 - 0.2 = 1.5 A$$

To find the p.d. across the capacitor

$$V_E - 2 - 0.2 \times 2 = V_G$$

$$\therefore V_E - V_G = 2.4 \text{ V}$$

$$\text{or } V = 24 \text{ V}$$

$$\therefore \text{Energy stored in capacitor} = \frac{1}{2} CV^2$$

$$= \frac{1}{2} \times 5 \times 10^{-6} \times (2.4)^2 = 1.44 \times 10^{-5} \text{ J}$$

Q.13. An electrical circuit is shown in Fig. Calculate the potential difference across the resistor of 400 ohm, as will be measured by the voltmeter V of resistance 400 ohm, either by applying Kirchoff's rules or otherwise.

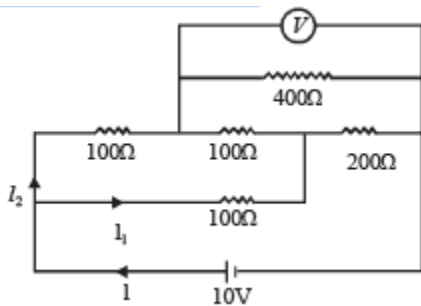

Ans. 6.67 V

Solution. We can redraw the circuit as.

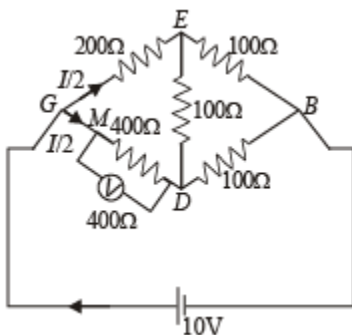

The equivalent resistance between G and D is

$$R_{GD} = \frac{400 \times 400}{400 + 400} = 200 \Omega$$

Since, $\frac{R_{GE}}{R_{GD}} = \frac{R_{EB}}{R_{DB}}$

∴ It is a case of balanced wheatstone bridge.

The equivalent resistance across G and B is

$$R_{GB} = \frac{300 \times 300}{300 + 300} = 150 \Omega$$

$$\therefore \text{Current } I = \frac{V}{R_{GB}} = \frac{10}{150} = \frac{1}{15} \text{ Amp.}$$

NOTE : Since $R_{GEB} = R_{GDB}$ the current is divided at G into two equal

parts $\left(\frac{I}{2}\right)$. The current $I/2$ further divides into two equal parts at M. Therefore the potential difference across the voltmeter

$$= \frac{I}{4} \times 400 = \frac{1}{15} \times \frac{400}{4} = \frac{20}{3} \text{ Volt} = 6.67 \text{ V}$$

Q.14. In the circuit shown in Figure, the battery is an ideal one, with emf V . The capacitor is initially uncharged. The switch S is closed at time $t = 0$.

(a) Find the charge Q on the capacitor at time t . (b) Find the current in AB at time t . What is its limiting value as $t \rightarrow \infty$:

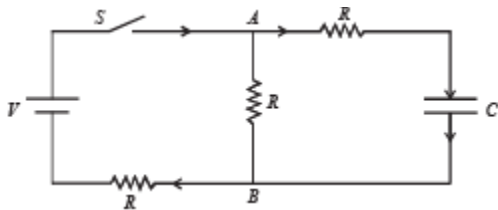

Ans. (a) $\frac{CV}{2}(1 - e^{-2t/3RC})$; (b) $\frac{V}{2R} - \frac{V}{6R}e^{-2t/3RC}$; $\frac{V}{2R}$

Solution. Let at any time t charge on capacitor C be Q . Let currents are as shown in fig. Since charge Q will increase with time ' t ' therefore $i_1 = dQ/dt$

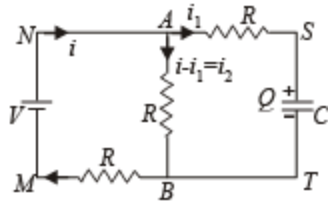

(a) Applying Kirchoff's second law in the loop MNABM

$$V = (i - i_1) R + iR \text{ or } V = 2iR - i_1R \dots (i)$$

Similarly, applying Kirchoff's second law in loop MNSTM, we have

$$V = i_1R + \frac{Q}{C} + iR \quad \dots(ii)$$

Eliminating i from equation (1) and (2), we get

$$\begin{aligned} V &= 3i_1R + \frac{2Q}{C} \quad \text{or} \quad 3i_1R = V - \frac{2Q}{C} \\ \text{or} \quad i_1 &= \frac{1}{3R} \left(V - \frac{2Q}{C} \right) \quad \text{or} \quad \frac{dQ}{dt} = \frac{1}{3R} \left(V - \frac{2Q}{C} \right) \\ \text{or} \quad \frac{dQ}{\left(V - \frac{2Q}{C} \right)} &= \frac{dt}{3R} \quad \text{or} \quad \int_0^Q \frac{dQ}{\left(V - \frac{2Q}{C} \right)} = \int_0^t \frac{dt}{3R} \end{aligned}$$

This equation gives $Q = \frac{CV}{2} (1 - e^{-2t/3RC})$

$$\begin{aligned} (b) \quad i_1 &= \frac{dQ}{dt} \\ i_1 &= \frac{d}{dt} \left[\frac{CV}{2} (1 - e^{-2t/3RC}) \right] \\ &= \frac{CV}{2} \times \frac{2}{3RC} \times e^{-2t/3RC} = \frac{V}{3R} e^{-2t/3RC} \end{aligned}$$

From equation (i)

$$i = \frac{V + i_1R}{2R} = \frac{V + \frac{V}{3} e^{-2t/3RC}}{2R}$$

∴ Current through AB

$$i_2 = i - i_1 = \frac{V + \frac{V}{3}e^{-2t/3RC}}{2R} - \frac{V}{R}e^{-2t/3RC}$$

$$i_2 = \frac{V}{2R} - \frac{V}{6R}e^{-2t/3RC}$$

$$i_2 = \frac{V}{2R} \text{ as } t \rightarrow \infty$$

Q.15. A thin uniform wire AB of length 1m, an unknown resistance X and a resistance of $12\ \Omega$ are connected by thick conducting strips, as shown in the figure. A battery and a galvanometer (with a sliding jockey connected to it) are also available. Connections are to be made to measure the unknown resistance X using the principle of Wheatstone bridge. Answer the following questions.

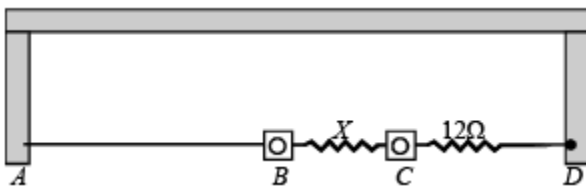

(a) Are there positive and negative terminals on the galvanometer? (b) Copy the figure in your answer book and show the battery and the galvanometer (with jockey) connected at appropriate points.

Ans. (a) No (b) $8\ \Omega$

Solution. (a) No. There are no positive and negative terminals on the galvanometer.

NOTE : Whenever there is no current, the pointer of the galvanometer is at zero. The pointer swings on both side of zero depending on the direction of current.

(b) ∵ Bridge is balanced $\frac{R_{AJ}}{R_{JB}} = \frac{0.6\rho}{0.4\rho} = \frac{12\ \Omega}{X}$

⇒ $x = 8\ \Omega$

where r is the resistance per unit length.

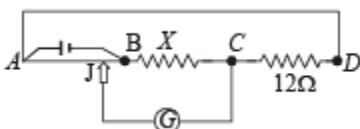

Q.16. How a battery is to be connected so that the shown rheostat will behave like a potential divider? Also indicate the points about which output can be taken.

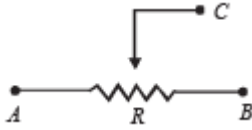

Ans. Battery connected across A and B. Output across A and C or B and C.

Solution. Battery should be connected across A and B. Output can be taken across the terminals A and C or B and C.

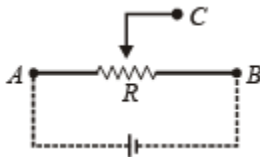

Q.17. Draw the circuit diagram to verify Ohm's Law with the help of a main resistance of $100\ \Omega$ and two galvanometers of resistances $106\ \Omega$ and $10\text{--}3\ \Omega$ and a source of varying emf. Show the correct positions of voltmeter and ammeter.

Solution. For the experimental verification of Ohm's law, ammeter and voltmeter should be connected as shown in the figure.

A voltmeter is a high resistance galvanometer ($106\ \Omega$) which is connected in parallel with the main resistance of $100\ \Omega$.

An ammeter is a low resistance galvanometer ($10\text{--}3\ \Omega$) which is connected in parallel with the main resistance.

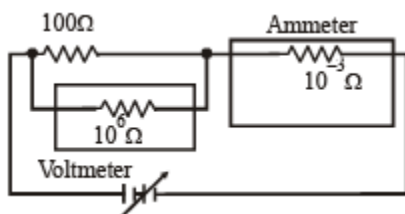

Q.18. An unknown resistance X is to be determined using resistances R_1 , R_2 or R_3 . Their corresponding null points are A, B and C. Find which of the

above will give the most accurate reading and why?

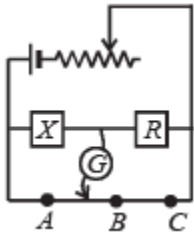

$$R = R_1 \text{ or } R_2 \text{ or } R_3$$

Ans. R2

Solution. KEY CONCEPT : At all null points the wheatstone bridge will be balanced

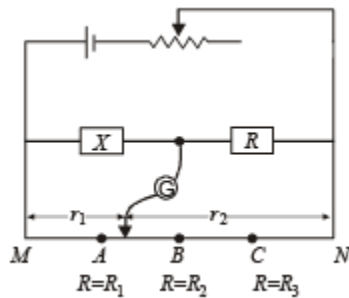

$$\therefore \frac{X}{r_1} = \frac{R}{r_2}$$

$$\Rightarrow X = R \frac{r_1}{r_2}$$

where R is a constant r_1 and r_2 are variable.

The maximum fractional error is

$$\frac{\Delta X}{X} = \frac{\Delta r_1}{r_1} + \frac{\Delta r_2}{r_2}$$

Here, $\Delta r_1 = \Delta r_2 = y$ (say) then

For $\frac{\Delta X}{X}$ to be minimum $r_1 \times r_2$ should be max

$$[\because r_1 + r_2 = c \text{ (constt.)}]$$

Let $E = r_1 \times r_2$

$$\Rightarrow E = r_1 \times (r_1 - c)$$

$$\therefore \frac{dE}{dr_1} = (r_1 - c) + r_1 = 0$$

$$\Rightarrow r_1 = \frac{c}{2} \Rightarrow r_2 = \frac{c}{2} \Rightarrow r_1 = r_2$$

$\Rightarrow R_2$ gives the most accurate value.

Q.19. In the given circuit, the switch S is closed at time $t = 0$. The charge Q on the capacitor at any instant t is given by $Q(t) = Q_0(1 - e^{-\alpha t})$. Find the value of Q_0 and α in terms of given parameters as shown in the circuit.

$$Q_0 = \frac{CVR_2}{R_1 + R_2}; \quad \alpha = \frac{R_1 + R_2}{CR_1R_2}$$

Ans.

Solution. Given $Q = Q_0[1 - e^{-\alpha t}]$ Here $Q_0 =$ Maximum charge and

$$\alpha = \frac{1}{\tau_c} = \frac{1}{C R_{eq}}$$

Now the maximum charge $Q_0 = C [V_0]$ where $V_0 =$ max potential difference across C

$$= C \left[\frac{V}{R_1 + R_2} \times R_2 \right]$$

and $\tau_c = C R_{eq}$

$$= C \left[\frac{R_1 R_2}{R_1 + R_2} \right] \therefore \alpha = \frac{1}{\tau_c} = \frac{R_1 + R_2}{CR_1R_2}$$

Match the Following

Each question contains statements given in two columns, which have to be matched. The statements in Column-I are labelled A, B, C and D, while the statements in Column-II are labelled p, q, r and s. Any given statement in Column-I can have correct matching with ONE OR MORE statement(s) in Column-II. The appropriate bubbles corresponding to the answers to these questions have to be darkened as illustrated in the following example :

	p	q	r	s	t
A	<input checked="" type="radio"/>	<input type="radio"/>	<input type="radio"/>	<input checked="" type="radio"/>	<input checked="" type="radio"/>
B	<input type="radio"/>	<input checked="" type="radio"/>	<input checked="" type="radio"/>	<input type="radio"/>	<input type="radio"/>
C	<input checked="" type="radio"/>	<input checked="" type="radio"/>	<input type="radio"/>	<input type="radio"/>	<input type="radio"/>
D	<input type="radio"/>	<input type="radio"/>	<input type="radio"/>	<input checked="" type="radio"/>	<input type="radio"/>

If the correct matches are A-p, s and t; B-q and r; C-p and q; and D-s then the correct darkening of bubbles will look like the given.

Q.1. Column I gives some devices and Column II gives some processes on which the functioning of these devices depend. Match the devices in Column I with the processes in Column II and indicate your answer by darkening appropriate bubbles in the 4×4 matrix given in the ORS.

Column I	Column II
(A) Bimetallic strip	(p) Radiation from a hot body
(B) Steam engine	(q) Energy conversion
(C) Incandescent lamp	(r) Melting
(D) Electric fuse	(s) Thermal expansion of solids

Ans. A \rightarrow s; B \rightarrow q; C \rightarrow p, q; D \rightarrow q, r



Solution.

A → s

Reason : Bimetallic strip is based on thermal expansion of solids.

B → q

Steam engine is based on energy conversion.

C → p, q

Incandescent lamp is based on energy conversion and radiation from a hot body.

D → q, r

Electric fuse is based on melting point of the fuse material which is turn depends on the heating effect of current.

Q.2. When two identical batteries of internal resistance 1Ω each are connected in series across a resistor R , the rate of heat produced in R is J_1 . When the same batteries are connected in parallel across R , the rate is J_2 . If $J_1 = 2.25 J_2$ then the value of R in Ω is

Ans. 4

Solution. Cells connected in series

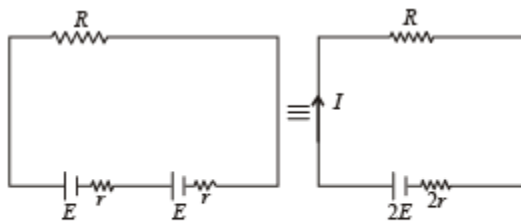

$$J_1 = I^2 R = \left(\frac{2E}{2r + R} \right)^2 \cdot R \quad \dots(1)$$

Cells connected in parallel

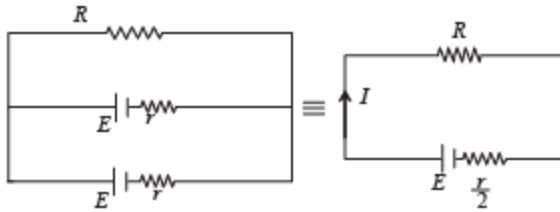

$$J_2 = I^2 R = \left(\frac{E}{R + \frac{r}{2}} \right)^2 \times R \quad \dots(2)$$

Given $J_1 = 2.25 J_2$

$$\frac{(2E)^2}{(2r + R)^2} R = 2.25 \frac{E^2}{\left(R + \frac{r}{2}\right)^2} R$$

$$\therefore \frac{4}{(2r + R)^2} = \frac{2.25}{\left(R + \frac{r}{2}\right)^2}$$

$$\therefore 4[R + 0.5]^2 = 2.25[2 + R]^2 \quad [\because r = 1\Omega]$$

$$\therefore 2(R + 0.5) = 1.5(2 + R)$$

$$\therefore R = 4\Omega$$

Q.3. At time $t = 0$, a battery of 10 V is connected across points A and B in the given circuit. If the capacitors have no charge initially, at what time (in seconds) does the voltage across them become 4 V? [Take : $\ln 5 = 1.6$, $\ln 3 = 1.1$]

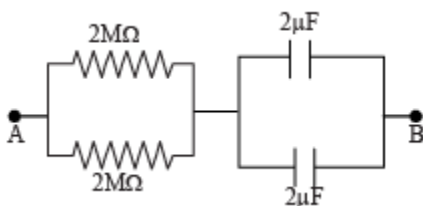

Ans. 2

Solution. The equivalent circuit is shown in the figure.

$$R = 1\text{M}\Omega, C = 4\mu\text{F}$$

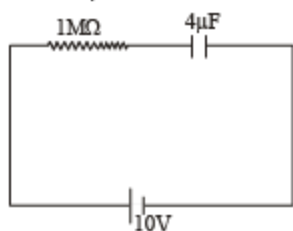

∴ The time constant $\tau = RC = 4 \text{ sec}$ The potential across $4\mu\text{F}$ capacitor at any time 't' is given as

$$V = V_0 \left[1 - e^{-\frac{t}{\tau}} \right] \quad 4 = 10 \left[1 - e^{-\frac{t}{4}} \right] \Rightarrow t = 2 \text{ sec}$$

Q.4. Two batteries of different emfs and different internal resistances are connected as shown. The voltage across AB in volts is

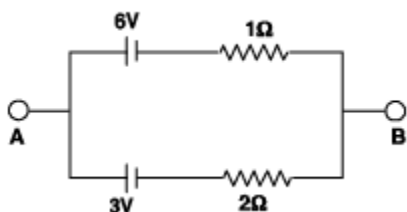

Ans. 5

Solution. Let i be the current flowing in the circuit. Apply Kirchhoff's law in the loop we get

$$-3 - 2i - i + 6 = 0$$

$$\therefore 3i = 3$$

$$\therefore i = 1 \text{ Amp}$$

Now let us travel in the circuit from A to B through battery of 6V, we get

$$V_A - 6 + 1 \times 1 = V_B$$

$$\therefore V_A - V_B = 5 \text{ volt.}$$

Q.5. A galvanometer gives full scale deflection with 0.006 A current. By



connecting it to a 4990Ω resistance, it can be converted into a voltmeter of range $0 - 30 \text{ V}$. If connected to $\frac{2n}{249} \Omega$ resistance, it becomes an ammeter of range $0 - 1.5 \text{ A}$. The value of n is

Ans. 5

Solution.

$$\left(\frac{I - I_g}{I_g} \right) S = \frac{V}{I_g} - R$$

$$\frac{1.5 - 0.006}{0.006} \times \frac{2n}{249} = \frac{30}{0.006} - 4990$$

$\therefore n \approx 5$

Q.6. In the following circuit, the current through the resistor $R (= 2 \Omega)$ is I amperes. The value of I is

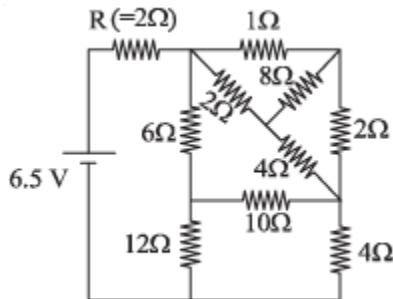

Ans. 1

Solution. The equivalent resistance of balanced wheatstone bridge is

$$R_{eq} = \frac{3 \times 6}{3 + 6} = 2 \Omega$$

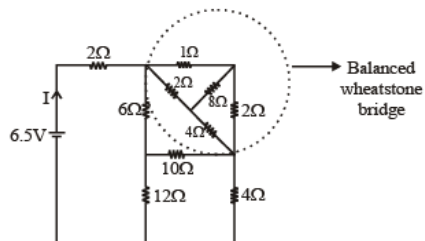

The equivalent resistance of balanced wheat stone bridge is

$$R_{\text{eq}} = \frac{6 \times 18}{24} = \frac{9}{2} \Omega$$

$$\therefore I = \frac{6.5}{2 + 4.5} = 1 \text{ A}$$

